

Customer Information Sheet

DRAWING No.: H3492-XX

SHEET 2 OF 2

IF IN DOUBT - ASK

(C)

NOT TO SCALE

THIRD ANGLE PROJECTION

ALL DIMENSIONS IN mm

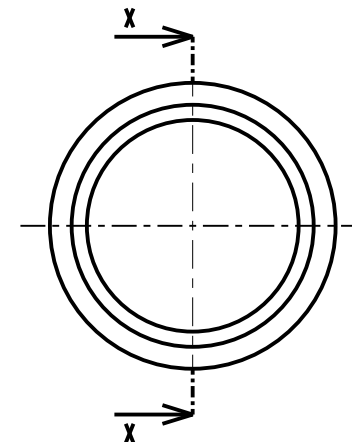
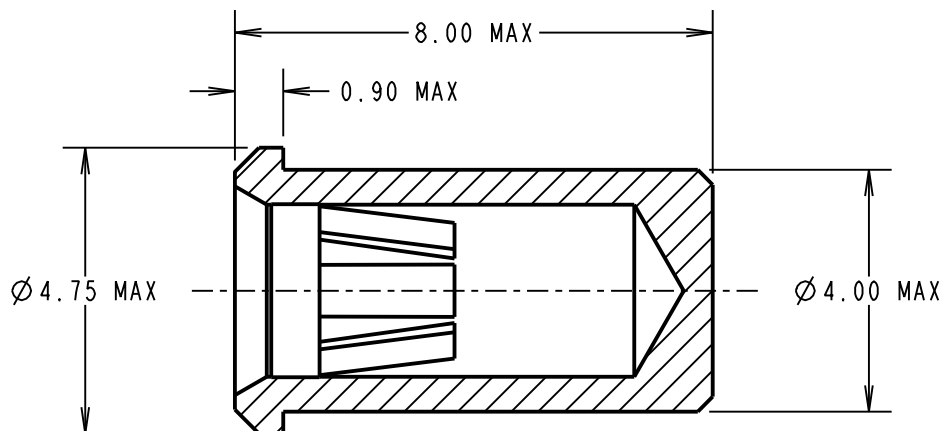

SPECIFICATION:

MATERIALS:

SHELL = BRASS CW614N TO BS EN 12164: 1998

CLIP = BERYLLIUM COPPER C17200 HM

FINISH:

01 = 0.10-0.15 μ GOLD CLIP, 3.5-5.0 μ 100% TIN SHELL

05 = 0.10-0.15 μ GOLD CLIP, 0.05-0.10 μ GOLD SHELL

46 = 2.4-3.6 μ 100% TIN CLIP, 3.5-5.0 μ 100% TIN SHELL

ELECTRICAL:

CURRENT RATING = 20A MAX

CONTACT RESISTANCE = 25 MILLIOHMS MAX

MECHANICAL:

DURABILITY = 01 - 500 CYCLES

05 - 500 CYCLES

46 - 50 CYCLES

INSERTION FORCE (\varnothing 2.00mm GAUGE) = 6N MAX, 3N MIN

WITHDRAWAL FORCE (\varnothing 2.00mm GAUGE) = 3N MAX, IN MIN

MATING PIN SIZE = \varnothing 2.3-2.0mm

CONTACT DEPTH = 4.1mm MAX

PIN LENGTH = 6.30mm MAX

ENVIRONMENTAL:

TEMPERATURE RANGE = -55°C TO +125°C

FOR COMPLETE MECHANICAL AND ELECTRICAL SPECIFICATION
SEE COMPONENT SPECIFICATION C031XX (LATEST ISSUE).

SECTION X-X

NOTES:

1. RECOMMENDED MOUNTING HOLE = \varnothing 4.02-4.12mm

ORDER CODE:

H3492-XX

FINISH:

01 = GOLD CLIP, TIN SHELL

05 = GOLD CLIP, GOLD SHELL

46 = 100% TIN CLIP, TIN SHELL

MGP	6	22.05.13	12096
NAME	ISS.	DATE	C/NOTE
APPROVED: MGP			
CHECKED: SB			
DRAWN:		A.LIOTTA	
CUSTOMER REF.:			
ASSEMBLY DRG:			

HARWIN

www.harwin.com
technical@harwin.com

THIS DRAWING AND ANY INFORMATION OR DESCRIPTIVE MATTER SET OUT HEREON ARE CONFIDENTIAL AND COPYRIGHT PROPERTY OF THE HARWIN GROUP AND MUST NOT BE DISCLOSED, LOANED, COPIED OR USED FOR MANUFACTURING, TENDERING OR FOR ANY OTHER PURPOSE WITHOUT THEIR WRITTEN PERMISSION.

TOLERANCES

X. = \pm 1mm
X.X = \pm 0.25mm
X.XX = \pm 0.10mm
X.XXX = \pm 0.01mm

ANGLES = \pm 5°

UNLESS STATED

MATERIAL:

SEE ABOVE

FINISH: SEE ABOVE

S/AREA: mm²

TITLE:

\varnothing 2.00mm SOCKET ASSEMBLY

DRAWING NUMBER:

H3492-XX

SHT
2 OF 2