

REVISIONS			
REV	DESCRIPTION	DATE	APPROVED
03 ₂	REVISED	DAC 3/22/99	<i>Tag</i> 3/21/99
B	PER EC 0U20-0615-00	20SEP01	<i>C. Hoang</i> 20SEP01

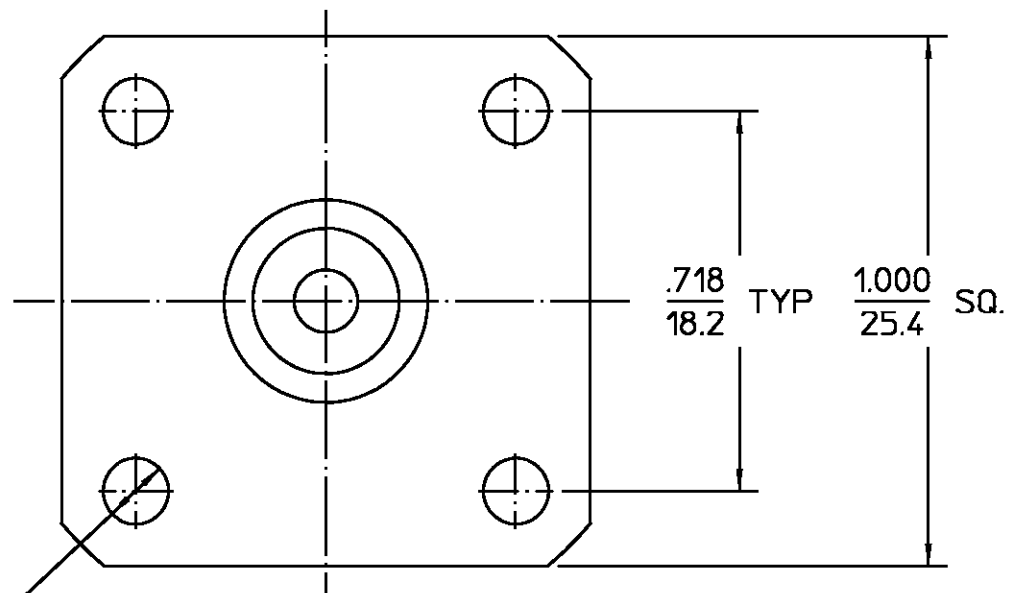
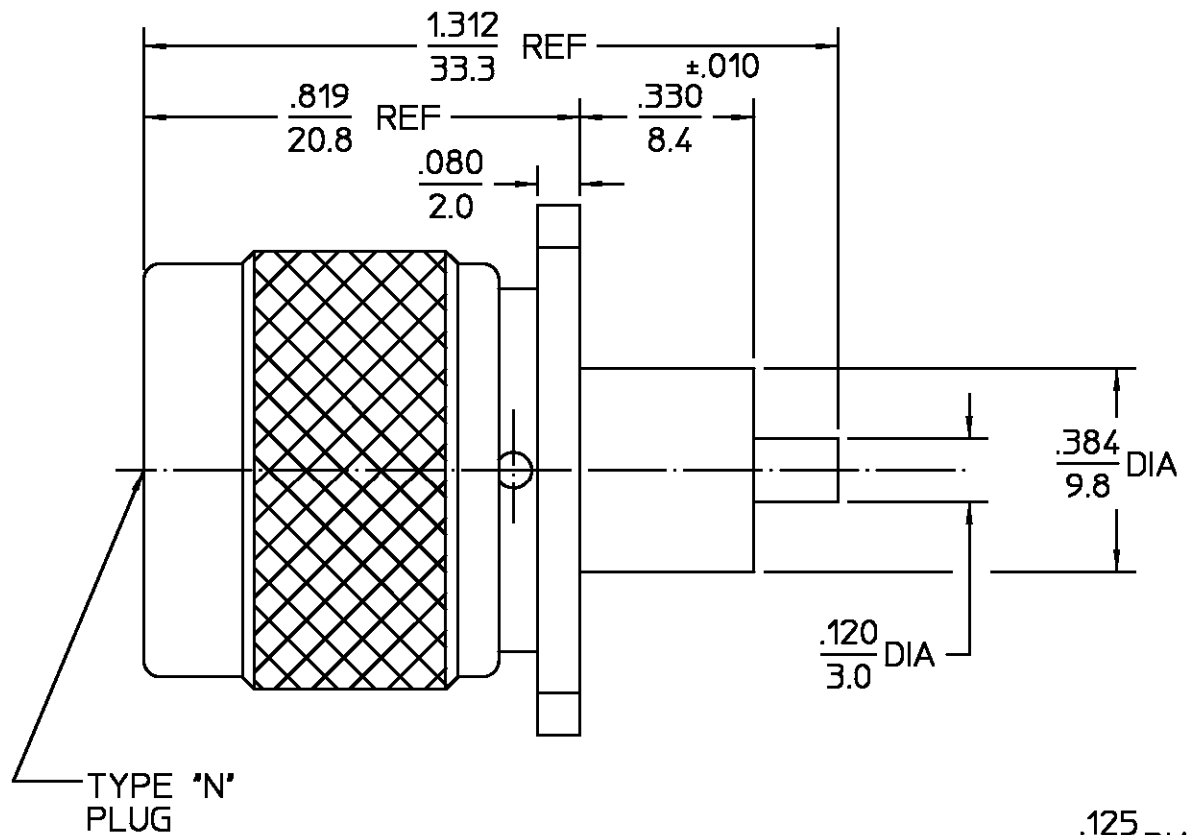

.125
3.2
DIA
(4 PLCS)

HOUSING	BRASS PER ASTM-B-16	NICKEL PLATE
COUPLING NUT	HALF HARD	QQ-N-290
DIELECTRIC	TFE FLUOROCARBON	N/A
	PER ASTM-D-1457	
CENTER CONTACT	BRASS PER ASTM-B-16,	GOLD PLATE PER
	HALF HARD	MIL-G-45204
RETAINING RING	BERYLLIUM COPPER PER	N/A
	ASTM-B-194, ALLOY	
	C17200, CONDITION H	
GASKET	SILICONE RUBBER PER	N/A
	ZZ-R-765	

COMPONENT	MATERIAL	FINISH
-----------	----------	--------

UNLESS OTHERWISE SPECIFIED DIMENSIONS ARE IN INCHES	DRAWN BY R.M.L.	DATE 3/5/73	AMP Incorporated 140 Fourth Avenue Waltham, MA 02451-7599
	CHECKED BY R.M.F.	3/5/73	
	APPD BY B.W.C.	3/5/73	

These drawings and specifications are the property of AMP Interconnect Div. and shall not be reproduced or copied or used in whole or in part as the basis for the manufacture or sale of item(s) without written permission.	USE ASSY PROCEDURE	TITLE TYPE N FLANGE MOUNT PLUG RECEPTACLE - STRAIGHT TERMINAL	
	NO. A.P. <u>N/A</u>	SIZE B	CODE IDENT NO. 26805
		3051-1201-10	REV 03 ₂
	SCALE 3:1	SHEET 1 OF 1	

NOTES:
1. CAPTURED CENTER CONTACT

.XXX = in
XX.X = mm

CUSTOMER DRAWING

AMP PART # 1057279-1
SHEET 1 OF 1 REV B